



**Installation, Operation, and Maintenance  
Manual**

*Gate, Globe, and Check Valves*

TNC Doc EDC 303, Revision 4, Issued April 2011



## **TABLE OF CONTENTS**

**1.0 - GENERAL**

**2.0 - INSTALLATION**

**3.0 - OPERATION**

**4.0 - MAINTENANCE**

**5.0 - BODY-BONNET/COVER BOLTINGS**

**6.0 - MAINTENANCE ON BOLTED BONNET GATE VALVES**

**7.0 - MAINTENANCE ON BOLTED BONNET GLOBE VALVES**

**8.0 - MAINTENANCE ON BOLTED CAP CHECK VALVES**

**9.0 - GATE, GLOBE, AND CHECK VALVES WELDED BONNET OR CAP**

**10.0 - POST WELD HEAT TREATMENT**

**11.0 - THE NAMEPLATE**

**12.0 - RECOMMENDED TORQUE VALUES**

**13.0 - VALVE COMPONENTS**



## 1.0 GENERAL

The majority of this information is common knowledge to experienced forged steel valve users. This information applies to all standard Smith API Std 602 Forged valves. When properly installed in applications for which they were designed, Smith valves will give long trouble free service.



***We do recommend however that this entire document be read prior to proceeding with any installation or repair.***

### 1.1 Responsibility For Valve Application

The End User is responsible for ordering the correct valves. SMITH VALVES are to be installed in the observance of the pressure rating and design temperature. Prior to installation, the valves and nameplates should be checked for proper identification to be sure the valve is of the proper type, material, and is of a suitable pressure class and temperature limit to satisfy the application requirements.



***Do not use any valve in applications where either the pressure or temperature is higher than the allowable working values. Also valves should not be used in service media if not compatible with the valve material of construction, as this will cause chemical attacks.***

### 1.2 Receiving Inspection and Handling

Valves should be inspected upon receipt to determine:  
Compliance to purchase order requirements.

Correct type, pressure class, size, body and trim materials and end connections (this information may be found on the nameplate or may be stamped on the body of the valve).  
Any damage caused during shipping and handling to end connections, handwheel or stem.



***The End User is advised that misapplication of the product may result in injuries or property damage. A selection consistent with the particular performance requirements is important for proper application.***



## 2.0 INSTALLATION



***Piping should be properly aligned and supported to reduce mechanical loading on the end connections.***

### 2.1 Installation Positions

Gate valves are usually bi-directional, and therefore may be installed in either direction. In some special cases, gate valves may be unidirectional, in which case the direction of flow will be indicated on the valve body.

Globe and Check valves are unidirectional, and have the direction of flow indicated on the valve body.

Smith piston and ball check valves are recommended for use only in horizontal lines with the cover facing up.

Spring loaded Smith piston and ball check valves are recommended for use in horizontal lines only, but may be installed with the cap facing down as well as up.

Smith swing check valves may be installed in horizontal lines or vertical lines where the direction of flow as indicated on the valve body is upwards.

### 2.2 Preparation for Installation

Remove protective end caps or plugs, and inspect valve ends for damage to threads, socket weld bores or flange faces.

Thoroughly clean adjacent piping system to remove any foreign material that could cause damage to seating surfaces during valve operation.

Verify that the space available for installation is adequate to allow the valve to be installed and to be operated.



***Insufficient clearance for the stem in the fully open position may cause the valve to be inoperable. Inadequate clearance for valves may add mechanical loading to the valve ends. Sufficient clearance should be allowed for threaded valves to be “swung” during installation.***

### 2.3 End Connections



### 2.3.1 Threaded Ends

Check condition of threads on mating piping.

Apply joint compound to the male end of joint only. This will prevent compound from entering the valve flowpath.

Smith valves have wrenching lugs forged onto the body ends. Wrenches should be used on the valve end closest to the joint being tightened.

### 2.3.2 Flanged Ends

Check to see that companion flanges are dimensionally compatible with the flanges on the valve body and make sure sealing surfaces are free of dirt.

Install the proper studs and nuts for the application and place the flange gasket between the flange facings.



***Stud nuts should be tightened in a criss-cross pattern in equal increments to ensure proper gasket compression.***

### 2.3.3 Socket weld Ends

Remove all grease, oil or paint from the pipe that is to be welded into the valve and from the valve end connections.

Insert the pipe into the valve end connection until it bottoms out in the socket weld bore. Withdraw the pipe 1/16" so that a gap remains between the pipe and the bottom of the socket weld bore to prevent cracks (ASME B16.11). Tack the pipe into the valve and complete the fillet weld.



***Gate and Globe valves should be lightly closed to prevent damage to the seating surfaces and stem caused by thermal expansion during the socket welding process.***

### 2.3.4 Integrally Reinforced Extended Body Valves (IREB)

Smith integrally reinforced extended body valves are manufactured with an optional integral backing ring for ease of installation.

A pilot hole not greater than 1/16" larger than the backing ring diameter is drilled through the wall of the run pipe. Tack weld the valve onto the run pipe (two opposing points). Complete the weld to the outside diameter of the reinforced valve end.

## 2.4 Post-Installation Procedures

---



After installation, the line should be cleaned by flushing to remove any foreign material. When caustics are used to flush the line, additional flushing with clean water is required. The valve should be opened and closed after installation to ensure proper operating function.

With the line pressurized, check the valve end connections, body to bonnet/cover joints and stem packing area for leaks. The packing may have to be tightened to stop packing leakage at the system pressure.

### 3.0 Operation

Gate valves should be used only in the fully opened or fully closed position.

Globe valves should not be used continuously at openings less than 25%.



***Gate and Globe valves should not be left in the fully back seated position under normal operating conditions. The packing may dry out under these conditions and leak as the valve is closed.***

A cool valve may leak through the gland when opened to hot fluid. Wait before tightening the packing as the problem may go away.

Metal seated check valves (piston, ball and swing) are not zero leak devices and may “seep” in service. This type of valve should always be backed up with an isolation valve (either gate or globe)

### 4.0 MAINTENANCE

Proper PPE should be worn when preparing to service a valve. Observe the following general warnings:



- ***A valve is a pressurized device containing energized fluids and should be handled with appropriate care.***
- ***Valve surface temperature may be dangerously too hot or too cold to the skin.***
- ***Upon disassembly, attention should be paid to the possibility of releasing dangerous and or ignitable accumulated fluids.***
- ***Adequate ventilation should be available for service.***



Tools Required

Aside from standard wrenches (for bonnet cap screws and packing gland nuts) the only tool needed for Smith valve maintenance is a packing hook.

Packing

Special care is to be placed in the tightening of gland nuts during installation, in order to get the proper packing adjustment and functionality.

The packing gland should be checked periodically in service and tightened as necessary to stop leakage around the stem. Tighten in a manner to develop uniform loading on the gland. Tighten only enough to stop the leak.

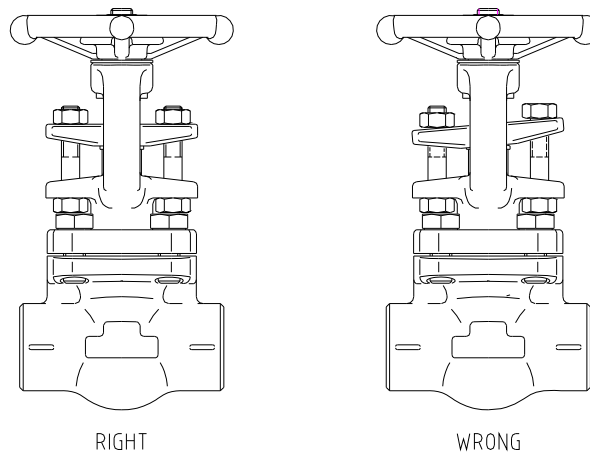

***Over tightening will cause the packing to fail prematurely as well as increasing the force required to operate the valve.***

If the leak cannot be stopped by tightening the gland nuts, it is necessary to add additional packing rings or completely repack the valve. While Smith gate and globe valves are equipped with a back seat feature, it is NOT RECOMMENDED TO REPACKED THEM UNDER PRESSURE.



***Back seating the valve and attempting to repack under pressure is hazardous and is not recommended. Rather than attempting to repack under pressure, it is preferable to use the backseat to control the stem leakage until a shutdown provides safe repacking conditions.***



The end rings (top and bottom) of the standard Smith graphite packing set have a diagonal cut that will allow them to be installed around the stem of an assembled valve. However, the factory installed intermediate graphite packing rings are die formed and have no end cut. As a result, these rings cannot be replaced without removing the valve bonnet. If the valve is to be repacked without removing the bonnet (see re packing the valve in line below), care must be taken when removing the original packing not to scratch the valve stem sealing surface.

Where it is necessary to repack the valve in line, a compatible ribbon packing system or equivalent braided packing stock should be used. The joints in the packing rings should be diagonally cut. When installing the rings, care should be taken to stagger the ring joints.

Other specialty packing such as V ring Teflon will require that the valve be disassembled if repacking is required.

### Stem Thread Lubrication

The operating Yoke Nut (Item 14) of Smith OS&Y Gate and Globe valves requires proper lubrication to stem threads and or to bonnet. The recommended grease to be applied is Loctite 77164 or equivalent. The following is the proper grease application method:

- If valve is CLOSED:
  - Apply Grease below the yoke nut onto stem threads
  - Open Valve To the Full Open Position
  - Apply Grease to the stem thread protruding above the Yoke Nut
  - Close Valve to the Full Close position
  - Cycle 1 additional time Full open to full close to evenly apply grease inside yoke nut
- If valve is OPEN:
  - Apply Grease above the yoke nut onto stem threads
  - Close Valve To the Full Close Position
  - Apply Grease to the stem thread below the Yoke Nut
  - Open Valve to the Full Open position
  - Cycle 1 additional time Full open to full close to evenly apply grease inside yoke nut

## **4.1 Repairs**

Due to the relatively low replacement cost of standard carbon steel valves, it is usually less expensive to replace the complete valve than to have maintenance personnel effect repairs. Additionally, in the case of a gate valve, it must be removed from the line in order to replace seat rings. Generally, the only justifiable repairs are replacement of packing and gaskets as previously described.

Always replace the bonnet gasket whenever a valve is disassembled. Gasket seating surfaces should be scraped clean (avoid radial marks). Bonnet bolts should be tightened in a diagonal pattern at several different increasing torque settings until the final recommended torque value is attained.



### 5.0 BODY-BONNET/COVER BOLTINGS

Only proceed to this operation changing one bolt at a time to prevent losses of pressure on the gasket. If this is not possible, replace the body-bonnet gasket locking bolts in a crossed way (see figure) till torque are the same of Appendix C.

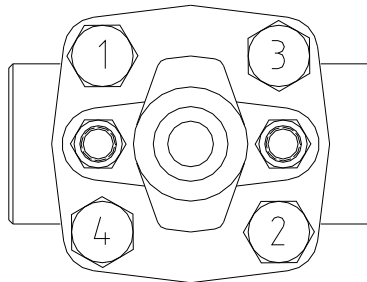

BOLTING SEQUENCE

### 6.0 MAINTENANCE ON BOLTED BONNET GATE VALVES

#### 6.1 WEDGE

- a. Proceed opening completely the valve assuring that the stem is brought to the backseat position.
- b. Loosen the body-bonnet bolting.
- c. Remove the bonnet-stem assembly. Take note of wedge sealing surfaces relative to the valve seats. Faces should be matched during re-assembly. Extract wedge from the stem T-head.

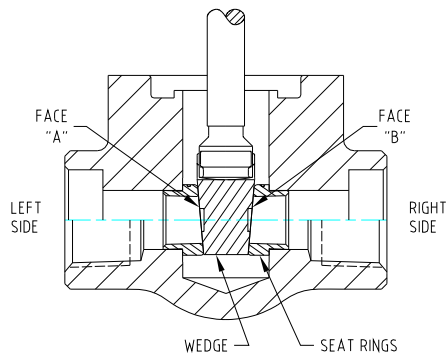

RIGHT POSITION

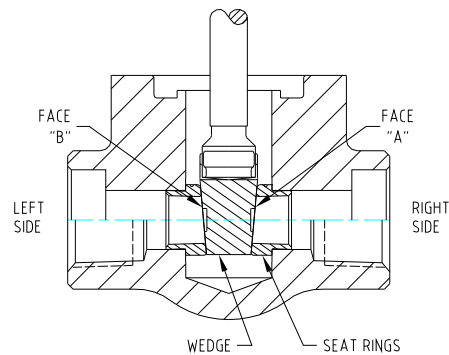

WRONG POSITION

- d. Check that no incisions or marks are on sealing surfaces. If any, use fine sand paper or emery cloth to eliminate them, assuring that the original planarity of these surfaces is not modified.
- e. Replace the gasket between body and bonnet, insert wedge in the stem T-head making sure that the faces are matched as noted above.



- f. Bring the bonnet-stem assembly to its original position and tighten the body-bonnet bolts as described in section 5.

## **6.2 STEM**

- a. Proceed opening completely the valve assuring that the stem is brought to the backseat position.
- b. Loosen the body-bonnet bolting.
- c. Remove the bonnet-stem assembly. Take note of wedge sealing surfaces relative to the valve seats. Faces should be matched during re-assembly. Extract wedge from the stem T-head.
- d. Disassemble the stem by turning it in the counter-clockwise direction.
- e. Make sure that the stem surface in contact with the packing is not damaged. If the stem is damaged beyond repair, call for a stem replacement or consider replacing the entire valve.
- f. Replace the stem by screwing it clockwise in the bonnet.
- g. Replace the gasket between body and bonnet, insert wedge in the stem T-head making sure that the faces are matched as noted above.
- h. Bring the bonnet-stem assembly to its original position and tighten the body-bonnet bolts as described in section 5.

## **6.3 SEATS**

No repairs are possible on seats of gate valves. Replacement of seat is possible, provided the right tools are available.

Blunt chisels and a hammer can be used to remove the old seats after removal of the bonnet-stem and wedge assembly. New seats must be assembled by expanding the ends as shown. We recommend that this process be carried out only in our factory where proper tooling is available, or call us for a replacement valve.

## **7.0 MAINTENANCE ON BOLTED BONNET GLOBE VALVES**

### **7.1 DISC and SEAT**

The seating surface is integral to the body. To check the seal characteristics between the disc and body seating area, we suggest the "BLUEING TEST":

- a. Proceed opening completely the valve, assuring that the stem is brought to the backseat position.
- b. Loosen the body-bonnet bolting.
- c. Remove the bonnet-stem and disc assembly. Apply some prussic-blue on the body seating surface.
- d. Place the bonnet-stem and disc assembly in the original position, and tighten the bolts as described in section 5.
- e. Take the valve in the close position, wait 20 seconds, and repeat steps "a" and "b" above.
- f. Remove the bonnet again, and check that the blue trace on the disc and the body is



uniformly present on the contact surfaces. If this has not occurred there are two possibilities:

- There are incisions or marks on sealing surfaces, either the disc or the body. Check and, if any, use fine sand paper or emery cloth to eliminate them, taking care that the original planarity of these surfaces is not modified.
- Repair is not possible because great damage has occurred. Contact our sales department giving details as described later to receive a new disc and replace it.

g. Replace the body-bonnet gasket.

h. Reassemble the bonnet-stem and disc assembly and tighten bolts as described in section 5.

## **7.2 STEM**

a. Proceed opening completely the valve, assuring that the stem is brought to the backseat position.

b. Loosen the body-bonnet bolting.

c. Remove the bonnet-stem and disc assembly. Extract the disc from the stem end.

d. Disassemble the stem by turning it in the counter-clockwise direction.

e. Make sure that the stem surface in contact with the packing is not damaged. If the stem is damaged beyond repair, call for a stem replacement or consider replacing the entire valve.

f. Replace the stem by screwing it clockwise in the bonnet.

g. Replace the gasket between body and bonnet, insert disc into the stem end.

h. Bring the bonnet-stem assembly to its original position, and tighten the body-bonnet bolts as described in section 5.

## **8.0 MAINTENANCE ON BOLTED BONNET CHECK VALVES**

There are three types of check valves: ball, piston, and swing type.

### **8.1 BALL, PISTON, and their SEATS**

a. Seats are integral to the body.

b. Loosen the body-cover bolting.

c. Remove all parts, taking note of the order of disassembly.

d. Visual check all sealing surfaces.

e. No incisions or marks shall be on sealing surfaces.

f. If any on the piston or the body, use emery cloth to eliminate them, assuring that the original planarity of the surface is not modified.

g. If there are any incisions or marks on the ball, or the above step is not successful, contact our sales department giving details as described later to purchase a new ball, piston, or a replacement valve.

h. Replace the body-bonnet gasket.

i. Reassemble the valve in the reverse order of the disassembly, and tighten the bolts as described in section 5.



## **8.2 SWING TYPE VALVE**

- a. Loosen the body-cover bolting.
- b. Remove the cover.
- c. Visually check all sealing surfaces.
- d. No incisions or marks must be on sealing surfaces.
- e. If there are damages, proceed with the aid of a hinge pin extractor to disassemble the swing. Note the order of disassembly.
- f. If possible, use fine sand paper or emery cloth to eliminate incisions or marks, assuring that the original planarity of the surface is not modified. If results are not satisfactory, contact our sales department giving details as described later to purchase new parts or replace the entire valve.
- g. Replace the body-bonnet gasket.
- h. Reassemble the valve in the reverse order of the disassembly, and tighten the bolts as described in section 5.

## **8.3 SEAT FOR SWING TYPE VALVES**

Similar to the gate valve, only limited work is possible. Refer to the gate valve section 6.3.

## **9.0 GATE, GLOBE AND CHECK VALVES WELDED BONNET OR CAP**

The only one difference with respect to the above mentioned cases is that there is a weld between body and bonnet or cover.

Maintenance is only limited to the packing area.

## **10.0 PWHT (POST WELD HEAT TREATMENT)**

### **10.1 PWHT RESPONSIBILITY**

Smith is responsible for all valve fabrication PWHT during manufacture of valve. The end user is responsible for any PWHT required after welding the valve in line.

### **10.2 PWHT REQUIREMENTS / RECOMMENDATIONS**

PWHT shall be performed in accordance with the appropriate user's WPS-PQR instructions.

All heating shall be performed with localized heating equipment to minimize adverse effects to the rest of the valve. The heat band shall be extended to include the weld HAZ (heat affected zone) of the joints.

In the absence of a governing specification, the requirements of ASME B31.1 or B31.3 for PWHT shall be considered.

For NACE valves, a NACE qualified user's WPS shall be used.

***Furnace heating of a complete valve assembly is not recommended as supplied valve trim part material conditions can be adversely impacted and the packing and gasket may be damaged or destroyed.***



***Please note that welded bonnet valves cannot be disassembled without the removal of the weld. This design should not be used if the valve assembly must undergo PWHT in a furnace. In this case, a bolted bonnet design valve should be used.***

### 10.3 PWHT PROCEDURE

The following steps relate to post weld heat treatment of valve welded in line:

#### For bolted and welded bonnet valves (localized heating):

1. The valve to undergo PWHT shall be in the lightly closed position.
2. Place the localized heating equipment around the welded joint.
3. Heat to the desired temperature for the desired length of time.
4. Allow the heated assembly to cool before actuating the valve.
5. Make sure that no adverse effect has taken place during heating and that the valve is functional before proceeding.

#### For bolted bonnet valves (furnace heating):

Disassembly of bolted bonnet valves is permitted only when closed furnace PWHT is the only heating option. Care must be taken in that case in choosing a suitable controlled atmosphere type furnace in the effort to eliminate heat scale formation which may adversely impact the sealing surfaces. This procedure voids the API 598 pressure tests performed during manufacture of the valve.

1. Loosen and remove bonnet bolting.
2. Remove bonnet/stem/gate/disc/piston assembly.
3. The seat rings in gate valves should not be removed.
4. During disassembly of the gate valves, the gate and body shall be marked to ensure that the same gate goes back into the same valve body in the same orientation as it was removed. The gate shall not be rotated when reassembled.
5. Place only the valve body and welded piping in the furnace.
6. Heat to the desired temperature for the desired length of time.
7. Allow the heated assembly to cool.
8. During reassembly, care should be taken to ensure that seat rings have not become loose, rotated, or floated off the body during heating. Seats can be examined by inspecting reference marks on seat rings, see figure for more details. Seat ring reference marks should be parallel at top dead center of valve body, with a maximum





allowable seat rotation of +/- 3 degrees. Should the seat rings orientation mentioned above occurs, the valve will not function properly. The valve **must** be replaced or return to the manufacture for re-staking of seat rings in the body.

- 9. Replace a new bonnet gasket during reassembly following PWHT.
- 10. Cap screws should be re-installed using recommended bonnet cap screw torque values and practice from the IOM.
- 11. Cycle valve to ensure full open and close actuation and that seats are secured in place.

### 11.0 THE NAMEPLATE

Each SMITH valve is equipped with an identification nameplate, placed over the handwheel for gate and globe valves and on the cover of check valve.

SMITH nameplates are custom laser printed to prevent any possibility of counterfeit or imitation.

The following is an example. The figure shows several descriptive data. The meaning of each data is given below:

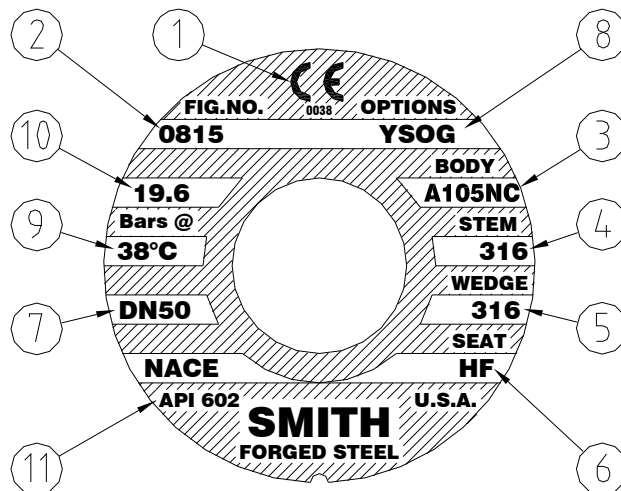

- 1. CE marking, which means that the valves comply with the requirements of European Pressure Equipment Directive 97/23/EC.
- 2. SMITH Valve’s catalogue figure number.
- 3. Shell material (body, bonnet, cover).
- 4. Stem material.
- 5. Closure member material. In case of hardface overlay, “HF” will be marked.
- 6. Seat material. In case of hardface overlay, “HF” will be marked.



- 7. Nominal diameter.
- 8. Valve material code option.
- 9. Reference ambient temperature per ASME B16.34
- 10. Maximum working pressure at reference ambient temperature per ASME B16.34
- 11. Applicable Design codes.

### 12. 0 RECOMMENDED TORQUE VALUES

Bolt Size	MATERIAL	TORQUE (ft-lbs)
<b>3/8 - 16</b>	Depending on material	<b>21 - 37</b>
<b>7/16 - 14</b>	Depending on material	<b>14 - 58</b>
<b>1/2 - 13</b>	Depending on material	<b>22 - 87</b>
<b>5/8 - 11</b>	Depending on material	<b>46 - 170</b>
<b>3/4 - 10</b>	Depending on material	<b>214 - 294</b>

### 13.0 VALVE COMPONENTS

<u>Gate Valves</u>		-	<u>Globe Valve</u>		-	<u>Check Valve</u>	
<u>Item</u>	<u>Description</u>	-	<u>Item</u>	<u>Description</u>	-	<u>Item</u>	<u>Description</u>
1	Body	-	1	Body	-	1	Body
2	Bonnet	-	2	Bonnet	-	2	Cap
3	Seat	-	3	Seat (integral)	-	3	Seat
4	Wedge	-	4	Disc	-	4	Piston/Ball
5	Stem	-	5	Stem	-	6	Gasket
6	Gasket	-	6	Gasket	-	7	Cap Bolts
7	Bonnet Bolts	-	7	Bonnet Bolts	-	17	Nameplate (not shown)
8	Packing	-	8	Packing	-	21	Cage
9	Gland	-	9	Gland	-	22	Spring
10	Gland Flange	-	10	Gland Flange	-	23	Drive Screws
11	Stud	-	11	Stud	-		
12	Gland Nut	-	12	Gland Nut	-		
14	Yoke Nut	-	14	Yoke Nut	-		
15	Thrustwasher	-	16	Handwheel	-		
16	Handwheel	-	17	Nameplate	-		
17	Nameplate	-	19	Handwheel Nut	-		
18	Lock Washer	-			-		
19	Handwheel Nut	-			-		

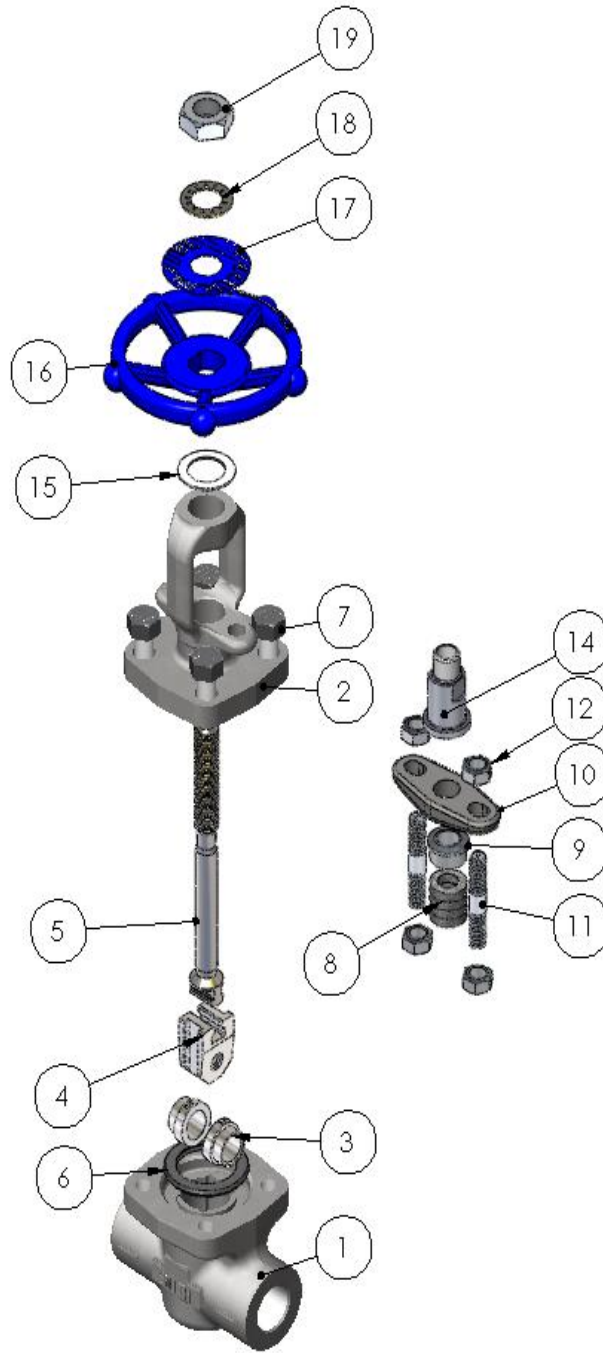

**GATE VALVE**

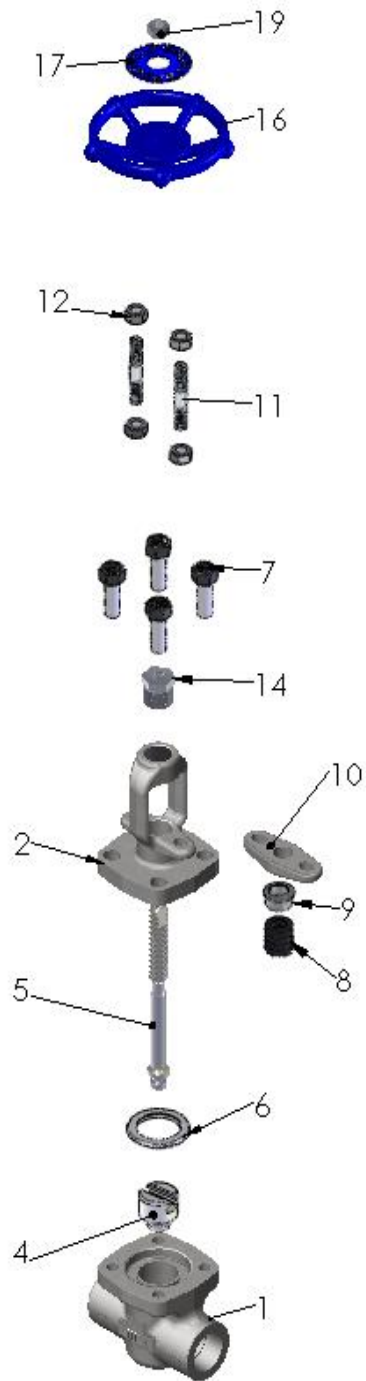

Globe Valve

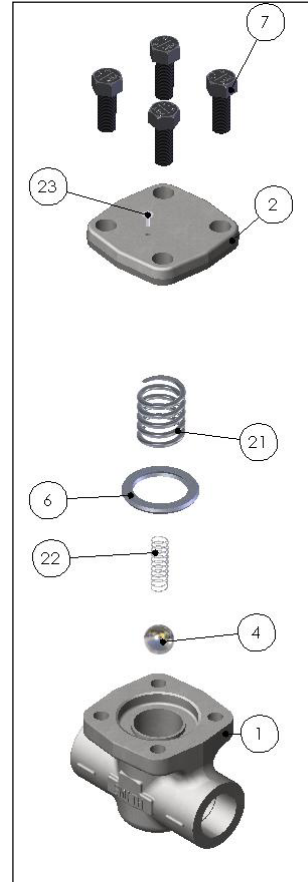
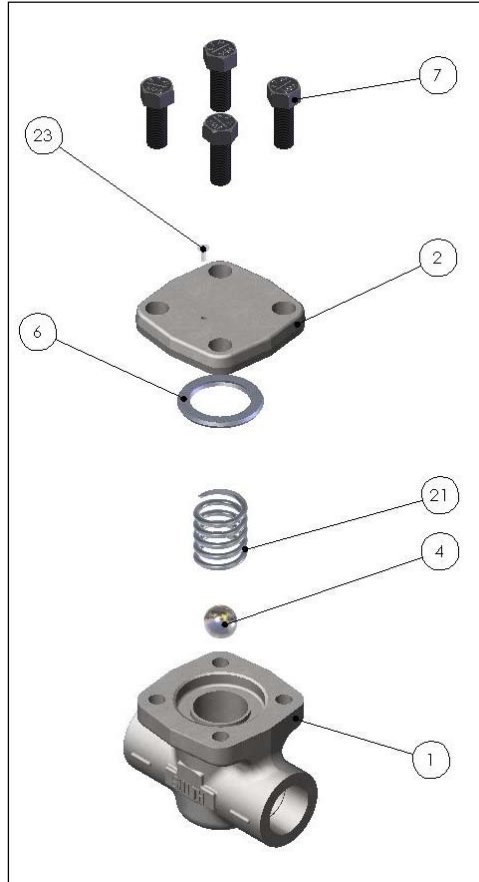
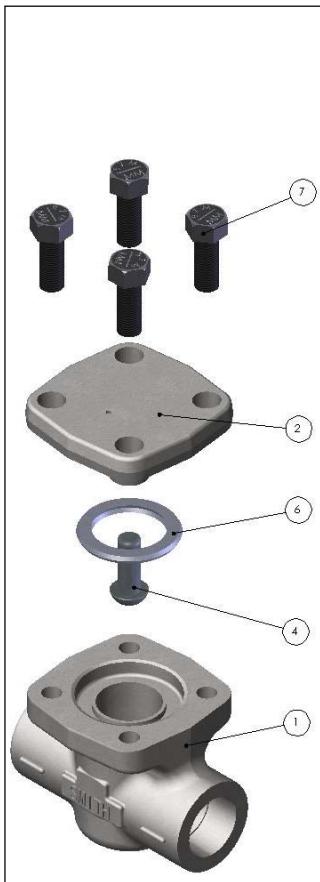

Check Valves